

DG6050C

RoHS

REACH

Inductance Range: 1.2~100μH

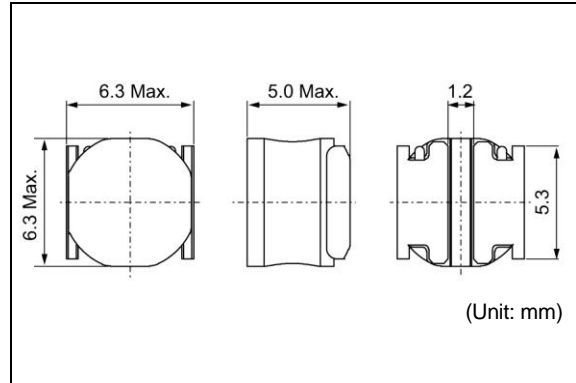

Recommended patterns
推荐焊盘尺寸

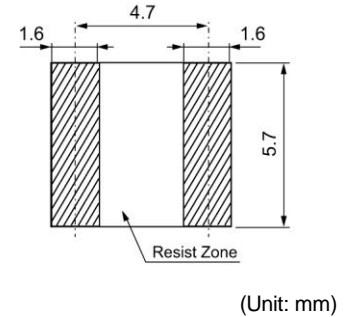

FEATURES 特点

- Low Profile (H=5.0mm Max).
- Magnetic Shield.
- Ideal for a variety of DC-DC converter inductor applications.
- Operating temperature range : -40~+85°C
- 小型薄型构造 (高度5.0mm max.)
- 闭磁路构造
- 最适用于各种设备的DC-DC Converter 中
- 使用温度范围: -40~+85°C

STANDARD PART NUMBERS 标准零件号码

TYPE DG6050C (Quantity/reel; 1500 PCS)

零件号码	电感值	公差	测试频率	直流电阻	最大允许直流电流(典型)	
Part Number	Inductance L(μH)	Tolerance (%)	Test Frequency (kHz)	DC Resistance (mΩ) Max. (Typ.)	Rated DC Current (A) Max. (Typ.)	
					ΔL/L=30%	ΔT=40[°C]
1264EY-1R2N=P3	1.2	±30	100	14.4 (12)	9.8 (13)	6.3 (7.4)
1264EY-1R5N=P3	1.5	±30	100	16.8 (14)	8.3 (11)	5.5 (6.5)
1264EY-2R2N=P3	2.2	±30	100	19.2 (16)	7.8 (10)	5.3 (6.2)
1264EY-3R3N=P3	3.3	±30	100	25.2 (21)	6.5 (8.6)	4.8 (5.6)
1264EY-4R7M=P3	4.7	±20	100	34.8 (29)	5.4 (7.2)	3.7 (4.4)
1264EY-6R8M=P3	6.8	±20	100	42.0 (35)	4.4 (5.9)	3.4 (4.0)
1264EY-100M=P3	10	±20	100	54.0 (45)	3.5 (4.7)	3.1 (3.6)
1264EY-150M=P3	15	±20	100	104.4 (87)	3.0 (4.0)	2.1 (2.5)
1264EY-220M=P3	22	±20	100	132.0 (110)	2.3 (3.0)	1.8 (2.2)
1264EY-330M=P3	33	±20	100	204.0 (170)	1.9 (2.5)	1.4 (1.7)
1264EY-470M=P3	47	±20	100	312.0 (260)	1.7 (2.3)	1.2 (1.4)
1264EY-680M=P3	68	±20	100	390.0 (325)	1.4 (1.9)	1.1 (1.3)
1264EY-101M=P3	100	±20	100	552.0 (460)	1.2 (1.6)	0.9 (1.1)

- (1) Inductance is measured with a LCR meter 4284A (Agilent Technologies) or equivalent. Test frequency at 100kHz
- (2) DC resistance is measured with 34420A (Agilent Technologies) or 3541(HIOKI). (Reference ambient temperature 25°C)
- (3) Maximum allowable DC current is that which causes a 30% inductance reduction from the initial value, or coil temperature to rise by 40°C, whichever is smaller. (Reference ambient temperature 20°C)

- (1) LCR仪表4284A (Agilent技术)或者功能相同的仪器在100kHz下测试电感值。
- (2) 通过数码万用表34420A (Agilent技术) 或者3541(HIOKI)测试直流电阻。(环境温度为25°C)
- (3) 允许最大直流电的范围是以下两者中比较小的一个: 引起电感值从最初值降低30%, 或者线圈温度升高40°C。(参考周围环境温度20°C)。